

BSMS Sample and Level Manual

Version 002



The information in this manual may be altered without notice.

Bruker accepts no responsibility for actions taken as a result of use of this manual. Bruker accepts no liability for any mistakes contained in the manual, leading to co-incident damage, whether during installation or operation of the instrument. Unauthorised reproduction of manual contents, without written permission from the publishers, or translation into another language, either in full or in part, is forbidden.

This Manual was written by

Beat Hugelshofer and Margat Werner

Desktop Published by

Beat Hugelshofer

Spectrospin AG, CH-8117 Fällanden

© August 1992: Spectrospin AG
Fällanden, Switzerland

P/N: Z 31187
DWG-Nr.: 858 002

Contents

Goto

1	General Description	3
1.1	Introduction	3
1.2	Basic Operation	3
1.3	Troubleshooting	3
2	Sample and Level Control Board SLCB	5
2.1	Introduction	5
2.2	Installation	7
2.3	Helium-Level (He-Level)	8
2.4	Nitrogen-Level (N-Level, Optional)	12
2.5	Lift	14
2.6	Spinrate	16
2.7	Scan Trigger	17
2.8	Turbine Temperature	17
2.9	Sample Changer Interface	17
2.10	Version of the Shim Upper Part	17
2.11	Technical Data	18
3	Pneumatic Module	21
3.1	Introduction	21
3.2	Installation	22
4	Schematics and Wiring	23
	Index	25
	List of Figures	27
	List of Tables	29

Introduction

1.1

This manual describes the subsystem of the BSMS (Bruker Smart Magnet control System) which handles the sample control, Helium (He) level measurement, and (optional) Nitrogen (N) level measurement systems. These sample and level functions require the following hardware:

1. One sample and level control board (SLCB).
2. One pneumatic module.
3. An air or nitrogen source (see Installation on page 7).
4. A Helium-level sensor.
5. A complete shim system with upper part.
6. Cable Z12152 (BSMS HE/N/BST).
7. A Nitrogen-level sensor (optional).

Basic Operation

1.2

All functions of the sample and level subsystem of the BSMS are accessible via the BSMS keyboard or BSMS Service Tool. Please read the corresponding section in the BSMS User's Manual.

Troubleshooting

1.3

An error in the sample and level subsystem is indicated by an error message on the BSMS keyboard and by the error LED of the SLCB. The error message has the format: ***E***: "Error number" ***SLCB*** "Error Text" ***press 'STD BY'***.

If such an error occurs, the basic troubleshooting procedure is as follows:

1. Check the power supply to verify that all power LED's (green) are lit. The ready LED is lit only if the local processor system is working correctly.
2. If there appear to be several errors originating from different boards, it is possible that they stem from an error on one particular board. First remove all the boards which show an error. Next, replace one board to see if an error still appears. Remove this board and replace the next board, and so on, until the board which is the source of the errors is identified. This procedure may also be used to stop recurring error messages (i.e., those which cannot be deleted by software).
3. Start the BSMS Service Tool (***[bsms]*** in UNIX).
4. In submenu ***[A]*** "***board functions SLCB...***" are functions for debugging the SLCB.

IMPORTANT: For more information please read the Service Tools Manual.

Sample and Level Control Board SLCB

2

Goto

Introduction

2.1

The SLCB is a smart controller board which is inserted into slot 5 of the BSMS front rack, as shown in Figure 1. It has the following functions:

1. Sample lift control.
2. Sample rotation control (spinner).
3. Helium (He) level measurement.
4. Nitrogen (N) level measurement (optional).

All functions are controlled by a microprocessor. The application software runs on a real time operating system and can be downloaded via the serial link to the computer (see BSMS Service Tool Manual).

For sample lift and sample rotation, the SLCB must be combined with a pneumatic module. The pneumatic module is plugged into the back rack of the BSMS (see Pneumatic Module on page 21).

All turbine commands are supported. Adjustments are made automatically but should be calibrated (see calibration procedures for the He and N-level, and sample lift and rotation systems described below).

The turbine temperature in the vicinity of the sample is measured by a PT-100 temperature sensor.

The shim upper section model type BST is automatically recognized by the BSMS.

Figure 1: SLCB in the BSMS (Front View)

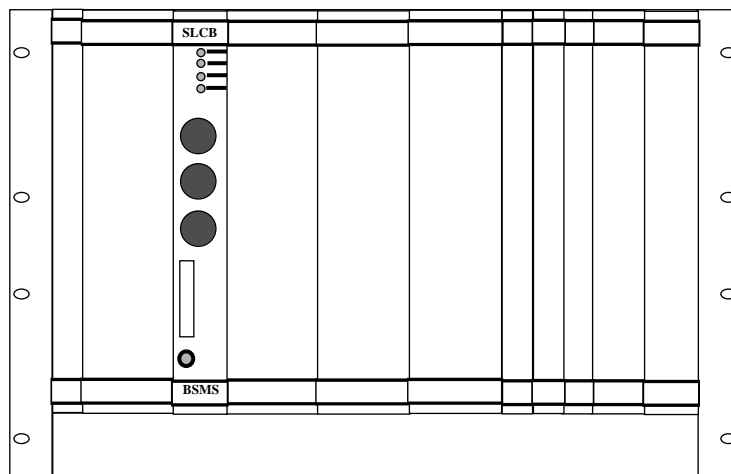

Sample and Level Control Board SLCB

Figure 2: SLCB Block Diagram

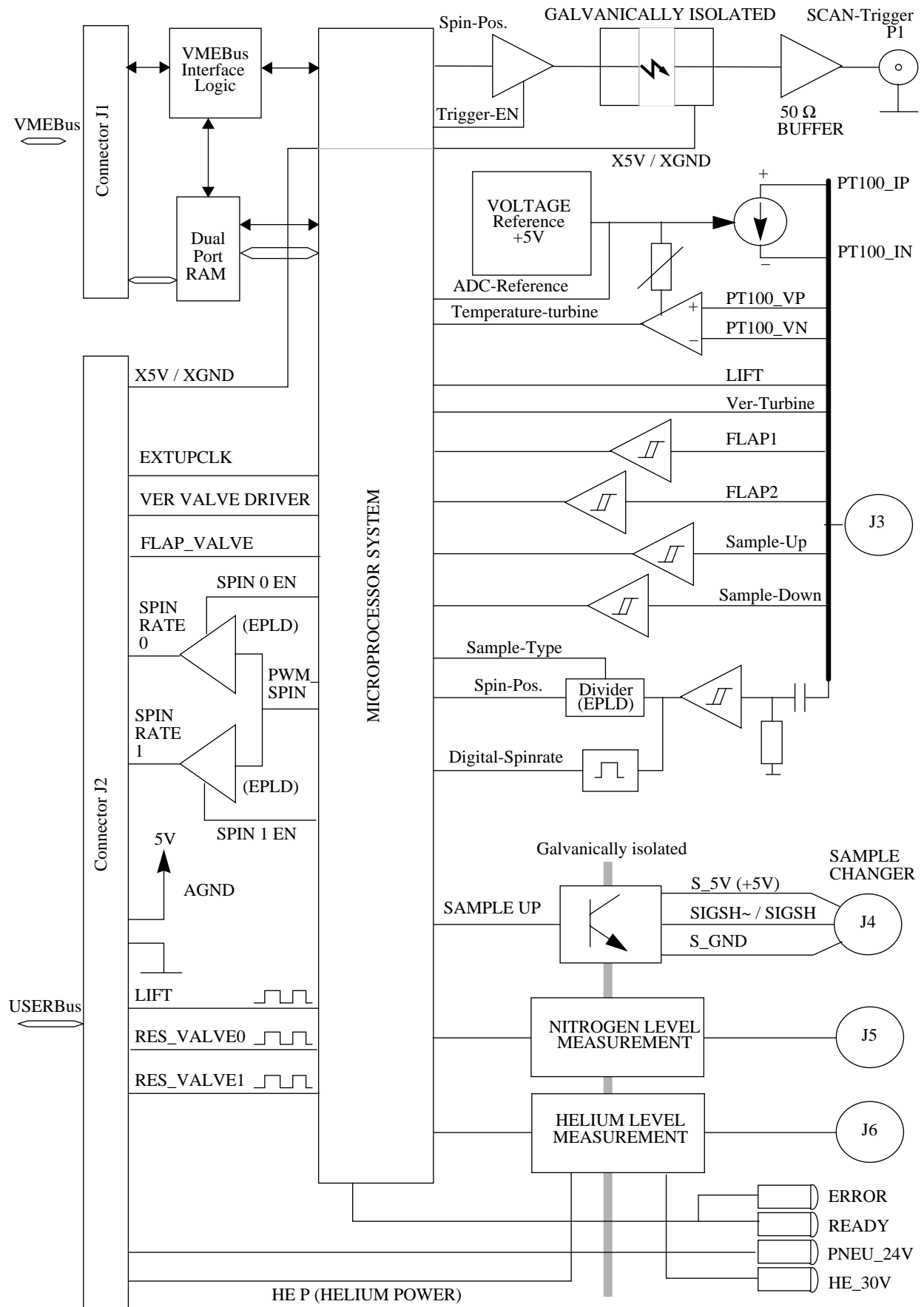

To install the SLCB please follow the guide below, making sure to do each step in the order given.

1. Insert the SLCB into SLOT 5 of the BSMS front rack, and the pneumatic module into the rear of the BSMS. Tighten the restraining screws.
2. Connect the spin and lift air hoses on the front of the pneumatic module to the shim upper part and console valve.
3. Connect the buffer to the front of the pneumatic module.
4. Connect the He-level, N-level (optional), and sample control cables to the front of the SLCB and to the shim upper part. Depending on shim upper part type, an interface cable (supplied in the cable set) must be attached.
5. Switch on the BSMS. After one second, check that all green LED's on the front of the SLCB are lit. No error LED's should be lit.
6. Check the software version with the BSMS Service Tool and download the new software if necessary.
7. Calibrate the He-level as described on page 10.
8. If the system has the N-Level option, calibrate the N-level as described on page 13.
9. Calibrate the lift airflow as described on page 15.
10. Calibrate the spinrate as described on page 16.

For monitoring the He-level, a He-level sensor is inserted into the top of the helium dewar. This He-level sensor is a superconducting sensor through which electrical current is caused to flow. When warm, the sensor has a resistance of about 100 Ω. The current resulting from the saturation resistance gives an indication of the actual He-level in the dewar.

Figure 3: He-Level Measurement Block Diagram

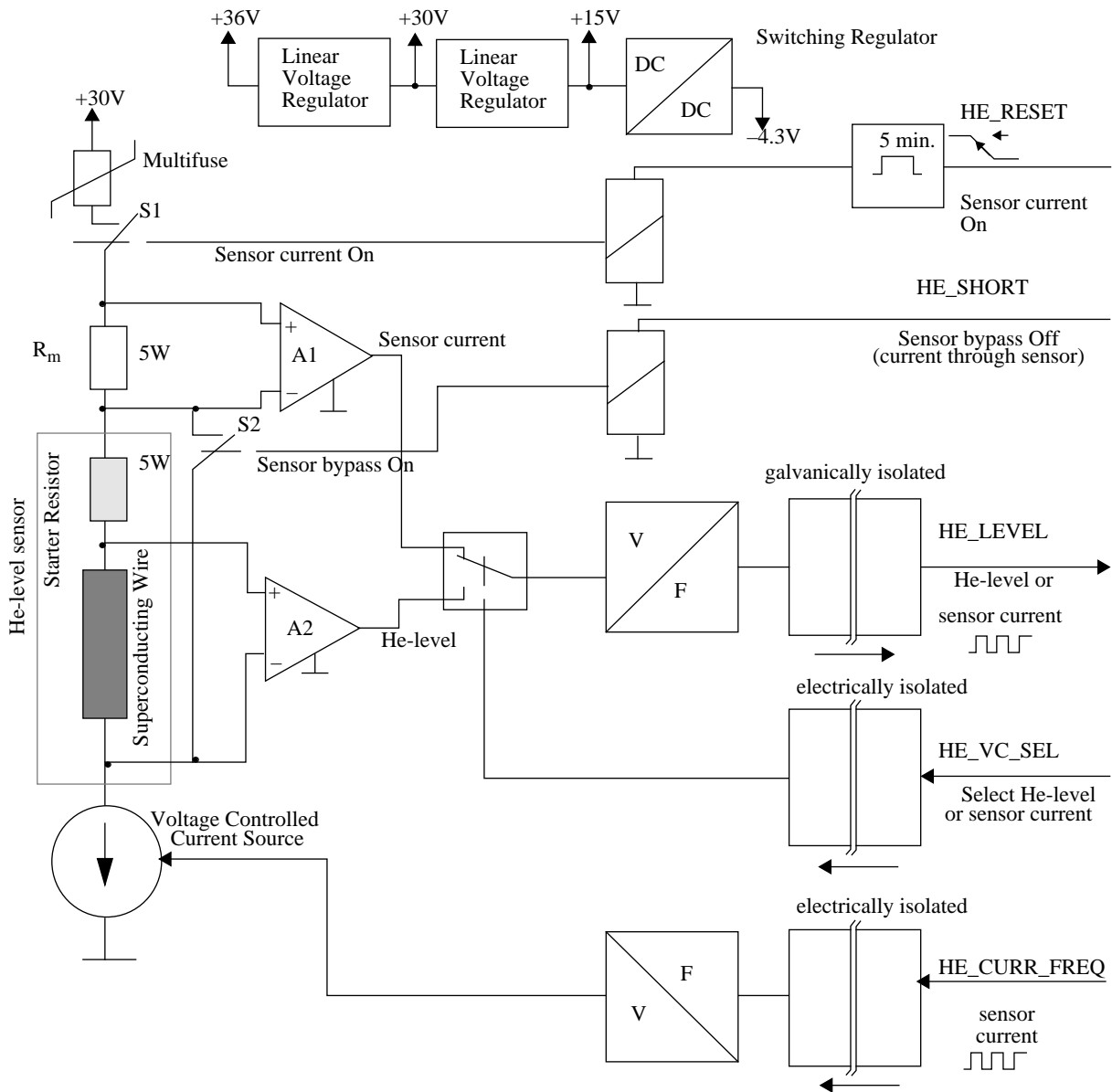

The He-level sensor is galvanically isolated from the BSMS electronics. The frequency modulated control and measuring signals are transmitted by optocouplers.

The He-level sensor current is produced by a controllable current source. The applied current is measured via the shunt R_m and the differential amplifier A_1 as a function test. The voltage across the sensor is measured by the differential amplifier

A₂. To avoid damaging the magnet, or evaporating too much helium through warming, the length of time the current is applied is limited. The supply of power is restricted to a maximum period of 5 minutes by the switch S1. As a further security measure, the S2 switch short-circuits the He-level sensor in between measurements to provide a current bypass.

Principle of the He-Level Measurement

2.3.1

Figure 4: He-Level Measurement Timing Diagram

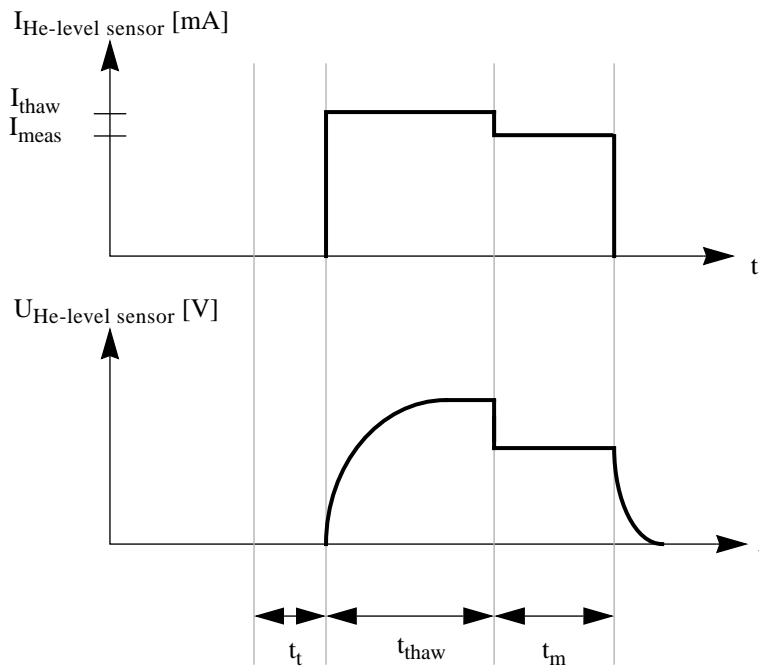

t_t : Duration of He-measurement system test. This precedes every He-level measurement.

t_{thaw} : Duration of sensor thaw. The thawing current (I_{thaw}) places the He-level sensor in a resistive state. As soon as the measuring current has established a stable value, thawing is halted. It can be assumed that the part of the sensor that is not immersed in the liquid helium has become resistive.

t_m : Duration of He-level measurement. To avoid unnecessary turbulence, a small sensor current (I_{meas}) is used to conduct the measurement itself.

I_{meas} : Current during measurement (default: 110 mA, see He-Level Calibration Procedure on page 10).

I_{thaw} : Current during sensor thaw. This has a value of $I_{meas} \times \text{MeasThawfactor}$. MeasThawfactor has a default value of 1.05, and can be changed from the computer but not the BSMS keyboard.

1. Enter menu mode on the BSMS keyboard ([2nd] and [Y³]).
2. Enter the Sec.Code ('4. Service', [ENTER], '4.1. Sec.Code', [ENTER], select code with control knob, [ENTER], a beep sounds if code is entered correctly, [ESC], and you are now in the menu '4. Service').
3. Enter the He-Function menu and set the alarm level according to the magnet type (see minimum He-level recommended in the manual for your particular magnet)('9. He-Function', [ENTER], '9.6. Alarm-Level', [ENTER], select value with control knob (default value: 100), [ENTER], '9.6. Alarm-Level').
4. Attach the correct 100% dummy connector (black indicator shunt, short circuit) in place of the He-level sensor and begin calibration ('9.3 100%', [ENTER], wait until calibration is finished and '100' appears on the right-hand side of the keyboard display, [ENTER], '9.3 100%').
5. Attach the correct 0% dummy connector (blue indicator shunt) in place of the He-level sensor and begin calibration ('9.2 0%', [ENTER], wait until calibration is finished and '0' appears on the right-hand side of the keyboard display, [ENTER], '9.2 0%', [ESC], '9. He-Function').
6. Save the calibration on the BSMS ('4. Service', [ENTER], '4.2. Save Config', [ENTER], a beep sounds and the message 'Done' appears).
7. Leave the menu ([ESC], [ESC], 'Standby') and check the calibration with the 0% and 100% dummy connectors ([2nd], [HELIUM-LEVEL], wait until measurement is finished and the level appears on the right-hand side of the display).
8. Measure the He-level in the dewar ([2nd], [HELIUM-LEVEL], wait until measurement is finished and the level appears on the right-hand side of the display). If the correct value is not obtained, de-ice the sensor ('9.4. De-Ice', [ENTER]) and redo the level measurement. Alternatively, the measurement current can be adjusted (see Adjusting the He-Measurement Current (I_{meas}) on page 11).
9. Raise the He-level sensor by 20% of its active length (see dewar manual).
10. Repeat step 8. The measured value should have decreased by approximately 10%.

N.B.: If the dummy connectors are not available, the 0% and 100% calibrations can be performed on a partially empty and a completely full He dewar, respectively:

1. For the 0% calibration, start with a partially empty dewar. Measure the He-level in the dewar with the dipstick.
2. Adjust the sensor so that its lower end is approximately 1 cm above the liquid He-level.
3. Do step 5 of the He-level calibration procedure.
4. For the 100% calibration, fill the dewar completely and do step 4 of the He-level calibration procedure.
5. Save and check these calibration values by following steps 6 to 10.

If the He-level is low, it is important to use the correct measurement current (I_{meas}) in order to obtain an accurate He-level measurement. The correct I_{meas} is determined by finding the “correct measuring area”, shown in Figure 5. The curves plotted in Figure 5 are the measured He-levels as a function of I_{meas} for actual He-levels of 10% and 35%. The following procedure should be followed for selecting the correct current when the He-level is below 20%.

Figure 5: Behavior of the He-Level Sensor

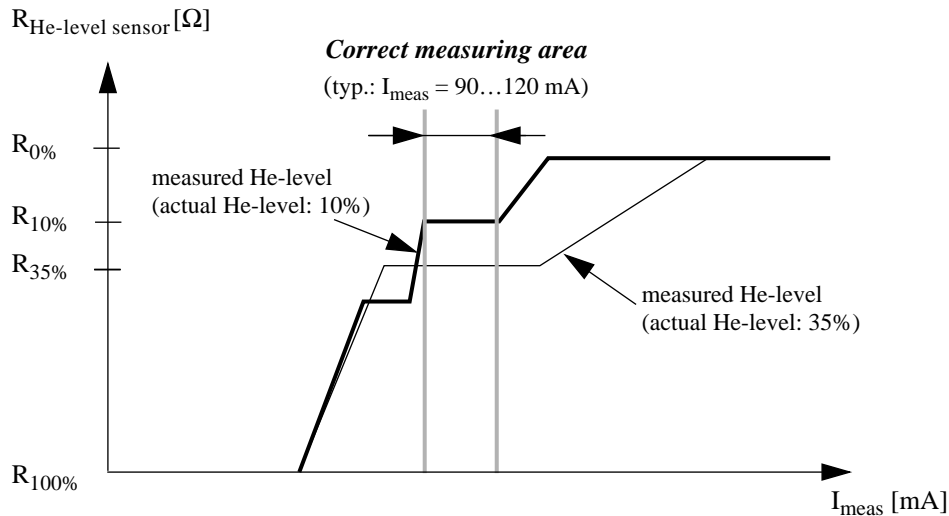

Change I_{meas} in 5 mA steps, measuring the He-level between changes. The correct measuring area is the region over which the measured He-level does not vary with I_{meas} , and is neither 0% nor 100%. Notice that for low He-levels there are multiple plateau regions, only one of which yields the correct measured He-level. Therefore, it is important to be sure to select the region which yields the lowest non-zero measured level. If the current values at either end of the correct measuring area differ by less than 10 mA, choose the maximum value. If they differ by more than 10 mA, choose a current value halfway between the two. Choosing I_{meas} by this procedure ensures that the He-level measurement will never give a falsely high result. For He-levels below 20%, the He-level measurement will give a falsely low result, but, unfortunately, this cannot be avoided.

Important: Do not choose a measurement current that is too low, since this will yield a measured He-level that is higher than the actual He-level!

N-level measurements are performed by a sensor that is encircled by a cylindrical conductor. The sensor and surrounding conductor form a capacitor which determines the oscillating frequency of a resonator (see Figure 6). The presence of nitrogen between the sensor and conductor changes the capacitance, and this in turn changes the oscillating frequency. The frequency change is then converted by the sensor electronics into a proportional voltage which is interpreted by the SLCB to provide the reading.

Figure 6: N-Level Measurement Block Diagram

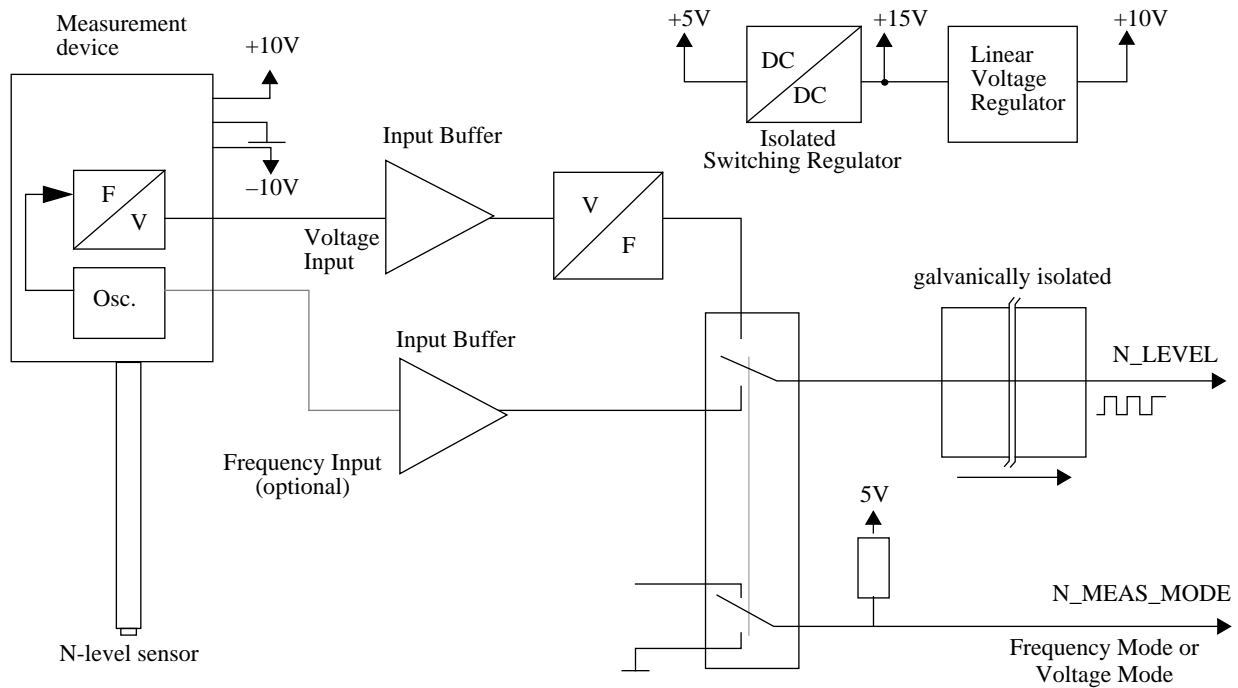

The measurement circuit on the SLCB board is separated galvanically from the other electronics. For transmission via the optocoupler the voltage is again translated into a proportional frequency.

An additional input allows the N-level sensor frequency to be measured directly.

1. Remove the N-sensor cap from the frequency-to-voltage converter (F/U-converter, Oxford product).
2. Enter menu mode on the BSMS keyboard ([*2nd*] and [*Y*³]).
3. Enter the Sec.Code (*'4. Service'*, [*ENTER*], *'4.1. Sec.Code'*, [*ENTER*], select code with control knob, [*ENTER*], a beep sounds if code is entered correctly, [*ESC*], and you are now in the menu *'4. Service'*).
4. Enter the N-Function menu and measure the voltage of the F/U-converter (*'8. N-Function'*, [*ENTER*], *'8.5 Voltage'*, [*ENTER*], and the actual voltage appears on the keyboard display).
5. Insert the N-sensor and fill the dewar with nitrogen until the lower end of the sensor is just above the N-level. Adjust the voltage (displayed on the keyboard) to 0V with **RV2** on the U/F-converter and exit the measurement function (*'8.5 Voltage'*, [*ESC*], *'8. N-Function'*).
6. Calibrate 0% (*'8.3 0%'*, [*ENTER*], wait until calibration is finished).
7. Again, enter the N-Function menu and measure the voltage of the F/U-converter (*'8. N-Function'*, [*ENTER*], *'8.5 Voltage'*, [*ENTER*], and the actual voltage appears on the keyboard display).
8. Fill the dewar completely. Adjust the voltage (displayed on the keyboard) to 0V with **RV2** on the U/F-converter and exit the measurement function (*'8.5 Voltage'*, [*ESC*], *'8. N-Function'*).
9. Calibrate 100% (*'8.4 100%'*, [*ENTER*], wait until calibration is finished).
10. Save the calibration on the BSMS (*'4. Service'*, [*ENTER*], *'4.2. Save Config'*, [*ENTER*], a beep sounds and the message *'Done'* appears).
11. Measure and check the N-level in the dewar (*'8.5 N-Level'*, [*ENTER*], wait until measurement is finished and the level appears on the right-hand side of the display) and leave the menu ([*ESC*], [*ESC*], *'Standby'*).

Figure 7: Lift Function Parameters

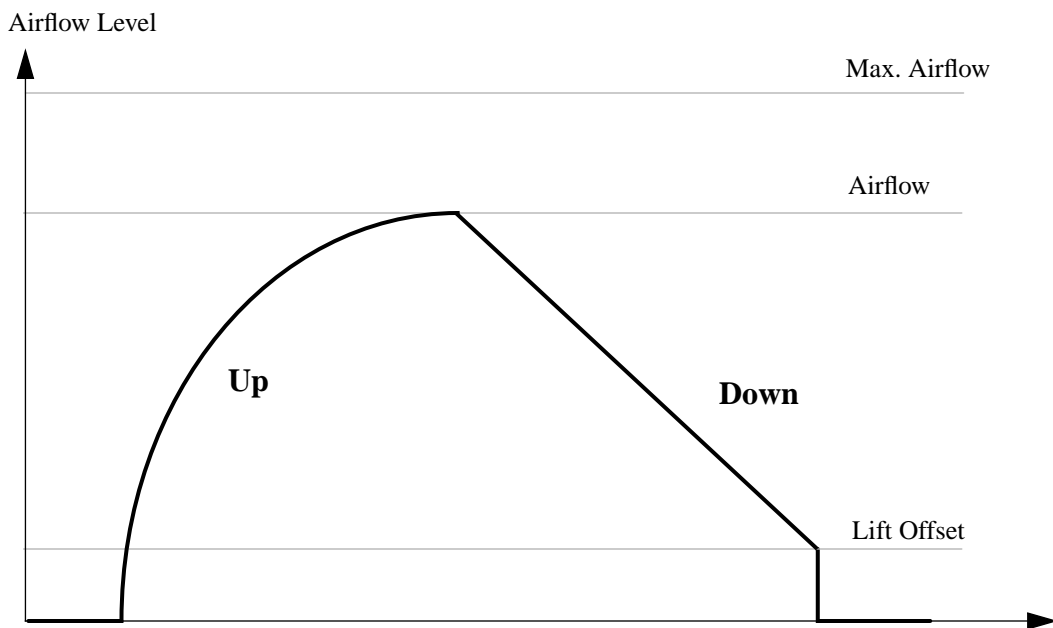

Max. Airflow:
Upper limit of airflow range.

Airflow:
Amount of air needed to maintain the sample position at the top of the shim tube. This can be set via the keyboard menu and is limited by Max Airflow. The airflow can be optimized to suit the size and material of the sample and spinner.

Lift Offset:
Airflow required to ensure sample does not fall too rapidly into the turbine area. This airflow should be enough to suspend the sample slightly above the turbine area.

Adjust the regulator valve through which the outside air/nitrogen enters the spectrometer console to limit the console pressure to 5 Bar.

N.B.: The difference pressure over the regulator valve should be greater than 0.5 Bar. The console pressure can be reduced to 4 Bar; however, this pressure is the absolute minimum for proper operation of lift and spinning.

1. Adjust the console pressure (see Console Pressure Adjustment Procedure on page 14).
2. Enter menu mode on the BSMS keyboard ([2nd] and [Y³]).
3. Turn on the sample lift ('1. Sample', [ENTER], '1.3 Lift On/Off', [ENTER], the LIFT ON LED lights).
4. Set the Max. Airflow to 0 and then adjust the Max. Airflow until the sample is comfortably suspended. ('1.4 Max Airflow', [ENTER], select value with control knob, [ENTER], '1.4 Max Airflow').
N.B.: It is better to set Max Airflow slightly too high rather than too low.
5. Adjust the Airflow until the sample is suspended optimally ('1.2 Airflow', [ENTER], select value with control knob, [ENTER], '1.2 Airflow').
6. Turn off the sample lift ('1.3 Lift On/Off', [ENTER], the LIFT ON LED goes off). If the sample lands heavily (i.e., with a dull thud) the Lift Offset may be increased in steps. ('1.5 Lift Offset', [ENTER], select value with control knob, [ENTER], '1.5 Lift Offset', [ESC], '1. Sample').
N.B.: It is important not to set the Lift Offset too high. Even with an appropriate Lift Offset, the sample will not always land lightly.
7. Save the calibration on the BSMS. ('4. Service', [ENTER], '4.2. Save Config', [ENTER], a beep sounds and the message 'Done' appears).
8. Exit menu mode ([ESC], [ESC], 'Standby').

1. Adjust the console pressure (see Console Pressure Adjustment Procedure on page 14).
2. Enter menu mode on the BSMS keyboard ([*2nd*] and [*Y*³]).
3. Set the desired maximum spinrate ('*1. Sample*', [*ENTER*], '*1.6 Max Spinrate*', [*ENTER*], select value with control knob, [*ENTER*], '*1.6 Max Spinrate*').
4. Start the automatic spinrate calibration ('*1.1 Spin Cal*', [*ENTER*], wait until calibration is finished and a beep sounds, [*ESC*], '*1. Sample*'). When using high spinrate values, place the cap on the top of the shim system. This improves the spinning behavior.
5. Save the calibration on the BSMS ('*4. Service*', [*ENTER*], '*4.2. Save Config*', [*ENTER*], a beep sounds and the message '*Done*' appears).
6. Exit menu mode ([*ESC*], [*ESC*], '*Standby*').

Scan Trigger

2.7

The scan trigger output delivers a short impulse for every full rotation of the spinner. This makes it possible to synchronize the beginning of an NMR measurement with the position of the sample. Note, however, that the scan trigger does not correspond to an absolute spinner or sample orientation, so the relationship between trigger and sample position may vary from sample to sample.

Turbine Temperature

2.8

The turbine temperature is monitored with a PT-100 four-wire measuring circuit.

Sample Changer Interface

2.9

The sample changer has its own pneumatic controller. The new shim upper part (BST) is equipped with a light switch to detect whether there is a sample present for pickup. This information is then passed to the sample changer via the sample changer interface of the BSMS. All turbine commands are supported. Adjustments are made automatically but should be calibrated.

Version of the Shim Upper Part

2.10

The shim upper part version can be read by the SLCB; however, this function is not supported for the old shim upper part (SOT72).

Table 1. Technical Data of the He-Level System

He-Level				
He measurement current	Range	40...150	mA	
	Resolution	1	mA	
	Accuracy	+/- 5	%	
	Default	110	mA	
	De-ice current	200	mA	
He measurement system	Range	0...100	%	Valid for a calibrated system only
	Resolution	+/- 1	%	
	Accuracy	+/- 4	%	For a He-level in the range 20%...100%

Table 2. Technical Data of the (Optional) N-Level System

N-Level				
N measurement voltage	Input Range	0...-8.0	V	
	Resolution	10	mV	
	Accuracy	+/- 5	%	
N measurement system	Range	0...100	%	Valid for a calibrated system only
	Resolution	+/- 1	%	
	Accuracy	+/- 3	%	

Table 3. Technical Data of the Lift

Lift				
Input pressure	Range	4...6	bar	
	Stability	+/- 0.5	bar	

Table 4. Technical Data of the Spinrate

Spinrate				
Input pressure	Range	4...6	bar	
	Stability	+/- 0.05	bar	
Spinrate control	Range	7...50	Hz	
	Resolution	1	Hz	
	Accuracy	+/- 5	%	Spinrate = 25

Table 5. Technical Data of the Scan Trigger

Scan Trigger				
Output (square)	High-Level	2.5	V	50 Ω load
	Low-Level	0	V	
	Duty cycle	50	%	
	Fall and rise time	160	μS	
	Frequency	Actual spin-rate	Hz	

Table 6. Technical Data of the Turbine Temperature

Turbine Temperature				
Measurement	Range	-150...150	°C	
	Resolution	1	°C	
	Accuracy	+/- 3	%	

Table 7. Technical Data of the Sample Changer Interface

Sample Changer Interface (Galvanically Isolated)				
Power Source	Input Voltage	5	V	
	Accuracy	+/- 10	%	
Output Current	Source max	4	mA	
	Sink max	-4	mA	

Table 8. Technical Data of the SLCB Inputs

SLCB Inputs				
FLAP1S, FLAP2S	Input Low Voltage	0...1.8	V	
	Input High Voltage	1.8...5	V	
SAMPLE_UPS, SAMPLE_DOWNS	Input Low Voltage	0...2.5	V	
	Input High Voltage	2.5...5	V	
LIFT~	Input Low Voltage	0...1	V	
	Input High Voltage	2.9...5	V	

Introduction

3.1

The pneumatic module contains all valves, valve drivers, and pneumatic connectors necessary to control the sample lift and spinner. The valve drivers are galvanically isolated. The lift and spin channel have their own input and output. For reasons of safety, it is necessary to connect a buffer to the lift system. The module is controlled by the SLCB.

Figure 8: Pneumatic Module in the BSMS (Front View)

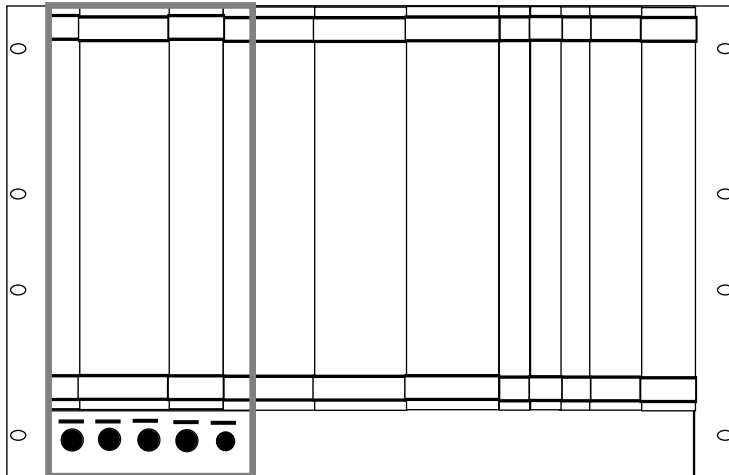

Figure 9: Pneumatic Module in the BSMS (Back View)

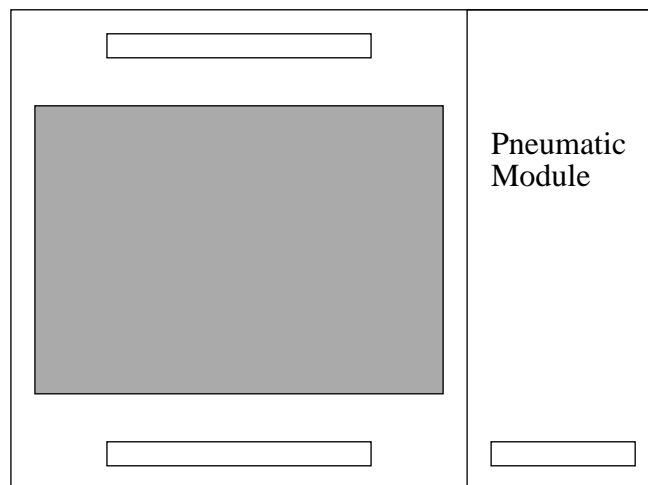
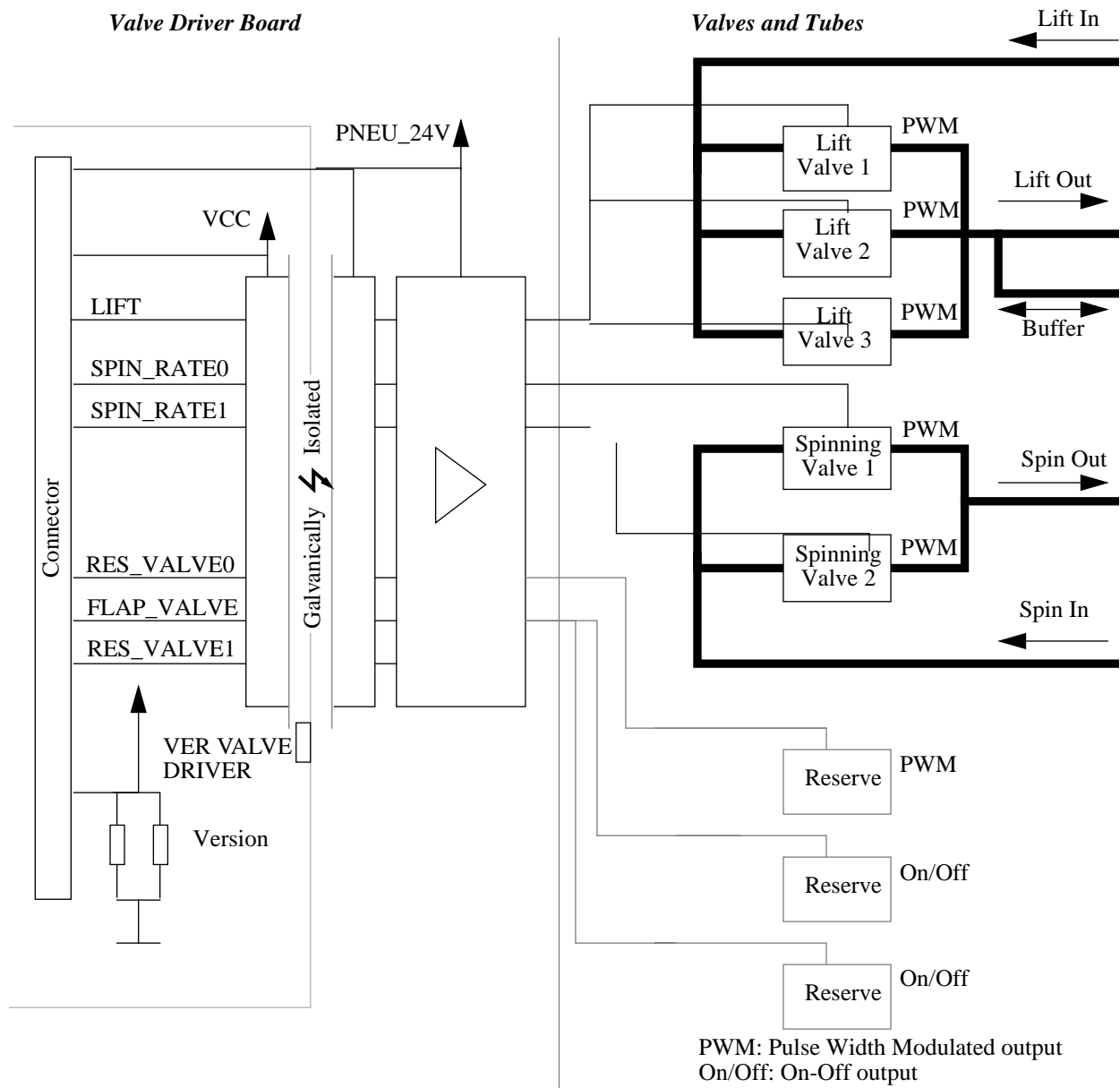

Figure 10: Pneumatic Module Block Diagram



Installation

3.2

For installation see the installation guide for the SLCB (Installation on page 7). The relevant steps are those concerning the lift and spin functions.

Table 9. Cable Wiring Contents:

Cable Name	DWG Number	Index	Number of Sheets
Cable RD 9.0 BSMS HE/N/BST	<u>Z3M-7521</u>	ZB	1
Cable RD 9.0 BSMS/BST			
Cable RD 9.0 HE-Level			
Cable RD 9.0 N-Level			

Index



B	BSMS3
	BSMS Service Tool3
H	He-level8
	Helium-Level.....8
L	Lift14
N	Nitrogen-Level.....12
	N-Level.....12
P	Pneumatic Module.....21
S	Service Tools manual3
	SLCB5
	Spinrate.....16
T	Technical Data.....18
	Troubleshooting3

List of Figures

1.General Description	3
2.Sample and Level Control Board SLCB	5
Figure 1: SLCB in the BSMS (Front View)	5
Figure 2: SLCB Block Diagram	6
Figure 3: He-Level Measurement Block Diagram	8
Figure 4: He-Level Measurement Timing Diagram	9
Figure 5: Behavior of the He-Level Sensor	11
Figure 6: N-Level Measurement Block Diagram	12
Figure 7: Lift Function Parameters	14
3.Pneumatic Module	21
Figure 8: Pneumatic Module in the BSMS (Front View)	21
Figure 9: Pneumatic Module in the BSMS (Back View)	21
Figure 10: Pneumatic Module Block Diagram	22
4.Schematics and Wiring	23

List of Tables

1.General Description	3
2.Sample and Level Control Board SLCB	5
Table 1. Technical Data of the He-Level System	18
Table 2. Technical Data of the (Optional) N-Level System	18
Table 3. Technical Data of the Lift	18
Table 4. Technical Data of the Spinrate	19
Table 5. Technical Data of the Scan Trigger	19
Table 6. Technical Data of the Turbine Temperature	19
Table 7. Technical Data of the Sample Changer Interface	20
Table 8. Technical Data of the SLCB Inputs	20
3.Pneumatic Module.....	21
4.Schematics and Wiring	23
Table 9. Cable Wiring Contents:	23

